

# Cap Screws & Bolts

# Head and Thread Dimensions

A325 & A490  
Structural Bolts

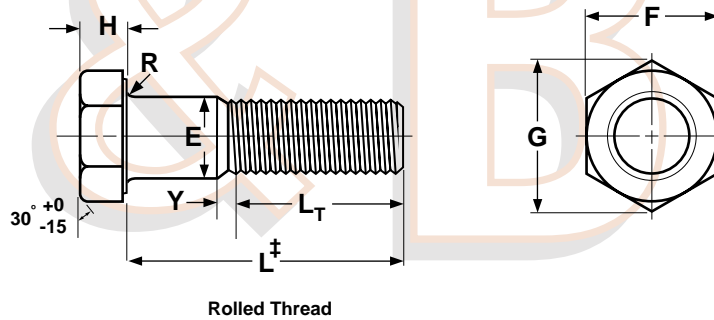
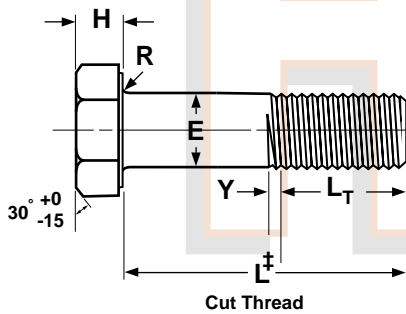

†Length of a structural bolt is measured from the underhead bearing surface to the extreme end of the bolt.

STRUCTURAL BOLTS, A325 & A490															ASME 18.2.6-1996	
Nominal Size or Basic Product Diameter		E		F			G		H			R		L <sub>T</sub>	Y	
		Body Diameter		Width Across Flats			Width Across Corners		Head Height			Radius of Fillet		Thread Length	Transition Thread Length	
		Max	Min	Basic	Max	Min	Max	Min	Basic	Max	Min	Max	Min	Ref	Max, Ref	
1/2	0.5000	0.515	0.482	7/8	0.875	0.850	1.010	0.969	5/16	0.323	0.302	0.031	0.009	1.00	0.19	
5/8	0.6250	0.642	0.605	1-1/16	1.062	1.031	1.227	1.175	25/64	0.403	0.378	0.062	0.021	1.25	0.22	
3/4	0.7500	0.768	0.729	1-1/4	1.250	1.212	1.443	1.383	15/32	0.483	0.455	0.062	0.021	1.38	0.25	
7/8	0.8750	0.895	0.852	1-7/16	1.438	1.394	1.660	1.589	35/64	0.563	0.531	0.062	0.031	1.50	0.28	
1	1.0000	1.022	0.976	1-5/8	1.625	1.575	1.876	1.796	39/64	0.627	0.591	0.093	0.062	1.75	0.31	
1 1/8	1.1250	1.149	1.098	1-13/16	1.812	1.756	2.093	2.002	11/16	0.718	0.658	0.093	0.062	2.00	0.34	
1 1/4	1.2500	1.277	1.223	2	2.000	1.938	2.309	2.209	25/32	0.813	0.749	0.093	0.062	2.00	0.38	
1 3/8	1.3750	1.404	1.345	2-3/16	2.188	2.119	2.526	2.416	27/32	0.878	0.810	0.093	0.062	2.25	0.44	
1 1/2	1.5000	1.531	1.470	2-3/8	2.375	2.300	2.742	2.622	15/16	0.974	0.902	0.093	0.062	2.25	0.44	

Tolerance on Length	Nominal Screw Size	Nominal Screw Length	
		Through 6 in.	Over 6 in.
	1/2	-0.12	-0.19
	5/8	-0.12	-0.25
	3/4 through 1	-0.19	-0.25
1 1/8 through 1 1/2	-0.25	-0.25	



**ASTM A325 BOLTS, Type 1**

<b>Description</b>	A heavy hex bolt made of medium carbon steel. The bearing surface shall be flat and washer faced, and the point is chamfered.
<b>Applications/ Advantages</b>	Commonly used in structural steel joints in heavy construction.
<b>Material</b>	Type 1 bolts shall be made from a carbon steel which conforms to the following chemical composition requirements-- <i>Carbon: 0.25-0.58%; Manganese: 0.57% minimum; Phosphorus: 0.048% maximum; Sulfur: 0.058% maximum</i>
<b>Heat Treatment</b>	Type 1 bolts shall be heat treated by quenching in a liquid medium from above the austenitizing temperature and then tempering by reheating to a temperature of at least 800°F.
<b>Hardness</b>	1/2" through 1" diameter, inclusive: Rockwell C24 - 35 1-1/8" through 1-1/2" diameter, inclusive: Rockwell C19 - 31
<b>Proof Load</b>	1/2" through 1" diameter, inclusive: 85,000 psi. 1-1/8" through 1-1/2" diameter, inclusive: 74,000 psi.
<b>Yield Strength</b>	1/2" through 1" diameter, inclusive: 92,000 psi. minimum 1-1/8" through 1-1/2" diameter, inclusive: 81,000 psi. minimum
<b>Tensile Strength</b>	1/2" through 1" diameter, inclusive: 120,000 psi. minimum 1-1/8" through 1-1/2" diameter, inclusive: 105,000 psi. minimum
<b>Plating</b>	See Appendix-A for plating information.



**Type 1**



**Type 3**

**ASTM A490 BOLTS, Types 1 & 3**

<b>Description</b>	A heavy hex bolt made of alloy steel. The bearing surface shall be flat and washer-faced, and the point is chamfered.
<b>Applications/ Advantages</b>	Used in structural steel joints in heavy construction when greater yield and tensile strengths than those of an A325 bolt are required. A Type 3 bolt is approximately twice as resistant to corrosion as a Type 1 bolt.
<b>Material</b>	Type 1 bolts shall be made from an alloy steel which conforms to the following chemical composition requirements-- <i>Carbon: 0.28-0.50% (for 1-1/2" diameter: 0.33-0.55%); Phosphorus: 0.045% maximum; Sulfur: 0.045% maximum.</i> Type 3 bolts shall be made from a corrosion resistant steel which conforms to the following chemical composition requirements-- <i>Carbon: 0.19-0.55%; Manganese: 0.37% minimum; Phosphorus: 0.045% maximum; Sulfur: 0.055% maximum; Copper: 0.63% maximum; Chromium: 0.42% minimum; Nickel: 0.17% minimum; Molybdenum: 0.14% minimum.</i>
<b>Heat Treatment</b>	Type 1 bolts shall be heat treated by quenching in oil from above the transformation temperature. Type 3 bolts shall be quenched in a suitable liquid from above the transformation temperature. Type 1 and Type 3 bolts shall be tempered by reheating to a temperature of at least 800°F.
<b>Hardness</b>	Rockwell C33 - 38
<b>Proof Load</b>	120,000 psi.
<b>Yield Strength</b>	130,000 psi. minimum
<b>Tensile Strength</b>	150,000 - 170,000 psi.
<b>Plating</b>	See Appendix-A for plating information.

\*\*Product standards require the manufacturer's head marking to appear on the top of all cap screws 1/4" diameter and larger. "X" represents one location such a marking may appear.