

METRIC FASTENERS

NUTS

Cage Style

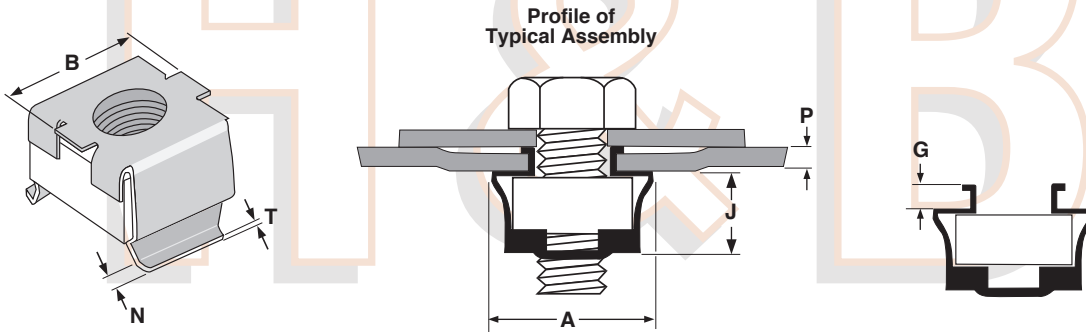

CAGE NUTS													
Screw Size	Kanebridge Part Number	G		B		A	J		N		T	P	
		Foot Gap		Cage Width (Static)		Cage Width (Assembled)	Cage Height		Foot Width		Material Thickness	Panel Range	
		Max	Min	Max	Min	Ref	Max	Min	Max	Min	Ref	Max	Min
M5 x 0.8	M5-025NCAG	.095	.065	.535	.505	.54	.265	.235	.070	.050	.020	.063	.025
M5 x 0.8	M5-064NCAG	.135	.105	.535	.505	.54	.265	.235	.070	.050	.020	.105	.064
M6 x 1.0	M6-064NCAG	.135	.105	.535	.505	.54	.265	.235	.070	.050	.020	.105	.064
M6 x 1.0	M6-093NCAG	.150	.120	.535	.505	.54	.265	.235	.070	.050	.020	.126	.093
(millimeters)		(dimensions shown in inches)											

Description	A free floating square nut retained within a spring steel cage. The cage has two retaining legs on the same side of the nut, positioned 180° from each other, that hold the nut in place at panel edges or center panel locations.	
Applications/ Advantages	More economical and easier to install than other heavy duty nuts for blind side applications. Free floating nut will compensate for poorly aligned holes. The square cage design keeps the nut from rotating during tightening. Cage nuts are successfully used in heavy duty farm machinery, rail cars, home entertainment components and heating equipment among other applications.	
Material	<i>Cage</i>	<i>Nut</i>
	SAE 1050 - 1065 spring steel	SAE 1018, 1108 or equivalent steel
Heat Treatment	Parts are quenched from the proper austenitizing temperature directly into a salt bath at between 590°F and 710°F. Parts are held at this quench temperature for a recommended period. Parts are then removed from the salt quenched and air cooled to room temperature.	
Hardness	Rockwell C 44 - 51	
Plating	Cage nuts are typically supplied with a zinc plating.	