

# Washers

# METRIC

# Flat Washers Large O.D.

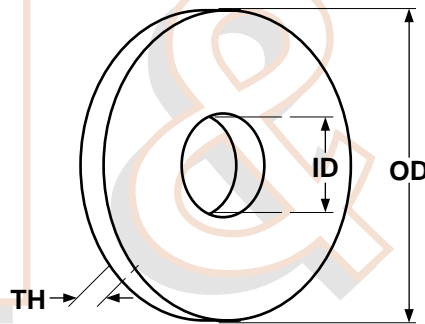

METRIC - FLAT WASHERS, LARGE O.D. (LARGE SERIES, GRADES A & C)						ISO 7093
Nominal Size	ID		OD		T	
	Internal Diameter		Outside Diameter		Thickness	
	Max	Min	Max	Min	Max	Min
3	3.38	3.2	9	8.64	0.9	0.7
3.5	3.88	3.7	11	10.57	0.9	0.7
4	4.48	4.3	12	11.57	1.1	0.9
5	5.48	5.3	15	14.57	1.4	1
6	6.62	6.4	18	17.57	1.8	1.4
8	8.62	8.4	24	23.48	2.2	1.8
10	10.77	10.5	30	29.48	2.7	2.3
12	13.27	13	37	36.38	3.3	2.7
14	15.27	15	44	43.38	3.3	2.7
16	17.27	17	50	49.38	3.3	2.7
20	22.52	22	60	58.1	4.6	3.4
24	26.84	26	72	70.1	6	4
30	34	33	92	89.8	7	5
36	40	39	110	107.8	9.2	6.8

	Steel	Stainless
Description	A thin, flat circular part with a centrally located hole with outside diameter three times the nominal thread diameter of the bolt to be used with it. Class 300 HV washers are also hardened and tempered.	
Applications/ Advantages	Washers are for assembly around a bolt or screw, between the bearing surface of the fastener and the part to which it is attached. Flat washers are used to improve stress distribution, and to span large clearance holes. This style washer is most similar to inch-sized fender washers.	Washers are for assembly around a bolt or screw, between the bearing surface of the fastener and the part to which it is attached. Flat washers are used to improve stress distribution, and to span large clearance holes. This style washer is most similar to inch-sized fender washers. <u>Stainless</u> washers are for use with austenitic stainless steel screws and nuts in general industrial applications where parts are subject to corrosion.
Material	Low or medium carbon steel	Austenitic stainless steel
Hardness	Grade A: HV 140 minimum (Rockwell B75 minimum) Grade C: HV 100 minimum (Rockwell B56.2 minimum)	HV 140 minimum (Rockwell B75 minimum)
Plating	See Appendix-A for information about the plating of flat washers.	