

CAP SCREWS & BOLTS **DIN 6921**
Serrated Flange Bolts

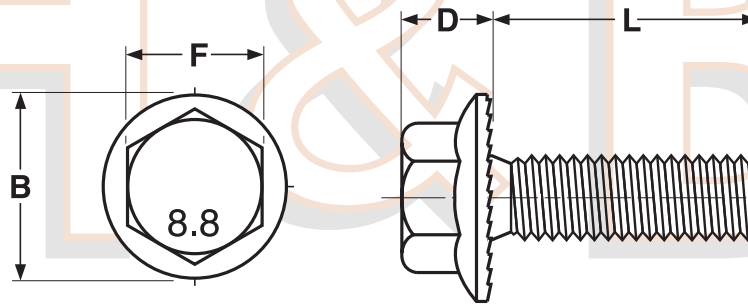

DIN 6921 SERRATED HEX FLANGE BOLTS						DIN 6921
Nominal Size	Thread Pitch	F		D	B	
		Width Across Flats		Total Head Height	Flange Diameter	
		Max	Min	Max	Max	Min
M5	0.8	8	7.78	5.4	11.8	-
M6	1	10	9.78	6.6	14.2	12.2
M8	1.25	13	12.73	8.1	18	16.8
Tolerance on Length	12 thru 16mm: ±0.35mm	20mm thru 30mm: ±0.42m		35 thru 50mm: ±0.5 mm		
	55 thru 80 mm: ±0.6 mm	90 thru 120 mm: ±0.7 mm		130 thru 180 mm: ±0.8 mm		

Description	A one-piece hex washer head bolt with a serrated bearing surface, made of medium carbon steel.
Applications / Advantages	Designed for use in applications where loosening forces, such as vibration, are present. After being installed, the serrations grip to the bearing surface so that significantly greater torque is needed to loosen the fastener than to tighten it. Can eliminate the need for a lockwasher or locknut in certain applications.
Material	Class 8.8 carbon steel chemical composition: Carbon- 0.15 - 0.55%; Phosphorous- 0.35% max; Sulphur- 0.35% max
Tempering Temperature	425° C Minimum
Tensile Strength	Class 8.8: 800 N/mm ² min.
Surface Hardness	HR30N 54.0 max.
Core Hardness	Class 8.8: Rockwell C22 - 32
Proof Stress	Class 8.8: 640 N/mm ² min.
Elongation after Fracture	Class 8.8: 12 mm
Plating	See Appendix-A for plating information