

Self-Tapping Screws

Head Dimensions

Torx® Flat &
Torx® Flat Undercut

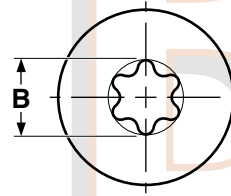
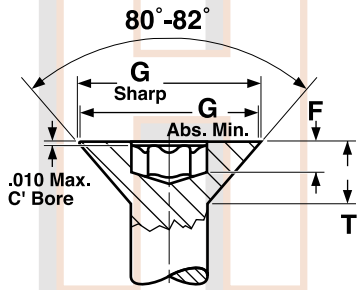

TORX® DRIVE FLAT HEADS FOR SELF-TAPPING SCREWS							Camcar, 4/99
Nominal Size	G		T	B	F	Fallaway	Torx® Driver Size
	Head Diameter		Head Height	Recess Diameter	Gauge Penetration		
	Max	Min	Ref	Ref	Min	Max	
2	.172	.147	.051	.069	.017	.014	T6
4	.225	.195	.067	.094	.028	.019	T8
5	.252	.220	.075	.111	.035	.022	T10
6	.279	.244	.083	.111	.035	.022	T10
8	.332	.292	.100	.132	.040	.026	T15
10	.385	.340	.116	.155	.050	.031	T20
1/4	.507	.452	.153	.200	.075	.040	T27

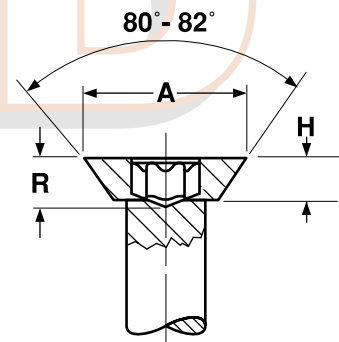
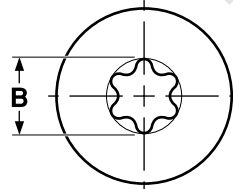
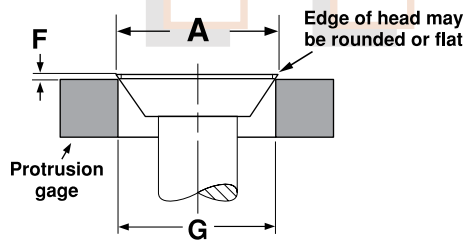

TORX® DRIVE FLAT UNDERCUT HEADS FOR SELF-TAPPING SCREWS								Camcar	
Nominal Size	A		H		B	F		Recess Penetration Gaging Depth	Torx® Driver Size
	Head Diameter		Head Height		Recess Diameter	Protrusion Above Gaging Diameter			
	Max	Min	Max	Min	Ref	Max	Min	Max	
4	.225	.195	.047	.038	.094	.032	.019	.020	T8
6	.279	.244	.059	.048	.111	.036	.021	.024	T10
8	.332	.292	.070	.058	.132	.039	.023	.035	T15
10	.385	.340	.081	.068	.155	.042	.025	.045	T20
12	.438	.389	.092	.078	.178	.045	.027	.050	T25
1/4	.507	.452	.107	.092	.200	.050	.029	.055	T27