

MACHINE SCREWS **ISO 14581**
Flat Six-Lobe

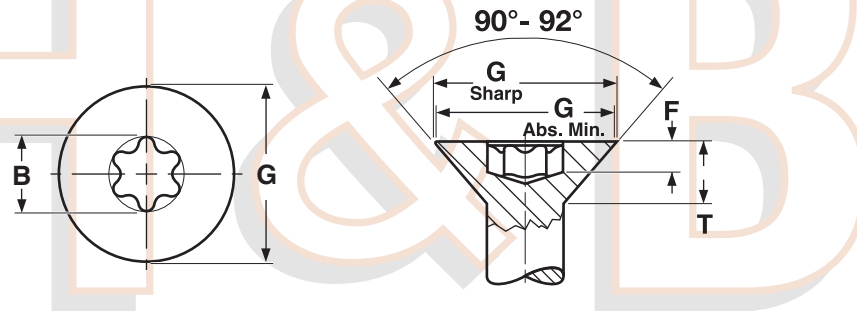

METRIC - ISO 14581 90° FLAT SIX-LOBE MACHINE SCREWS								ISO 14581
Nominal Size	Thread Pitch	G		T	B	F		Recess Size
		Head Diameter		Height of Head	Recess Diameter	Recess Penetration		
		Max	Min	Max	Ref	Max	Min	
M2	0.4	4.4	3.5	1.2	1.75	0.64	0.51	T6
M2.5	0.45	5.5	4.4	1.5	2.4	0.79	0.66	T8
M3	0.5	6.3	5.2	1.65	2.80	0.83	0.70	T10
M4	0.7	9.4	8.04	2.70	3.95	1.53	1.14	T20
M5	0.8	10.4	8.94	2.70	4.50	1.51	1.12	T25
M6	1	12.6	10.87	3.30	5.60	1.78	1.39	T30
M8	1.25	17.3	15.37	4.65	7.95	2.54	2.15	T45
Tolerance on Length		3mm: ±0.20			4-6mm: ±0.24		7-10mm: ±0.29	
		11-16mm: ±0.35			20-30mm: ±0.42		35-50mm: ±0.50	

Description	A countersunk head, straight shank fastener with a six-lobe shaped recess and a metric thread pitch designed to go through a hole or nut that is pre-tapped to form a mating thread for the screw. The head has a flat top surface and a cone-shaped bearing surface with a head angle of approximately 90 degrees.	
Applications/ Advantages	Ideal for applications where extra driving torque is required, especially where fasteners are subject to repetitive vibration; and where protrusion above the mating surface is unacceptable.	Used in applications where protrusion above the mating surface is unacceptable. The stainless variety is ideal for equipment used in the food industry or in corrosive environments.
Material	Class 8.8 Steel Medium carbon steel that conforms to the following chemical composition: Carbon: 0.25 - 0.55%; Phosphorous: 0.04% maximum; Sulfur: 0.05% maximum	Stainless Class A2-50
Heat Treatment	Class 8.8 machine screws shall be heat treated by quenching in a liquid medium from above the transformation temperature and reheating to a tempering temperature of 425°C.	
Hardness	Rockwell C 22 - 32	
Tensile Strength	640 N/mm ² minimum	
Plating	See Appendix-A	Stainless machine screws are usually supplied with a plain finish.