

HEX CAP SCREWS

Grade 9
Cap Screws

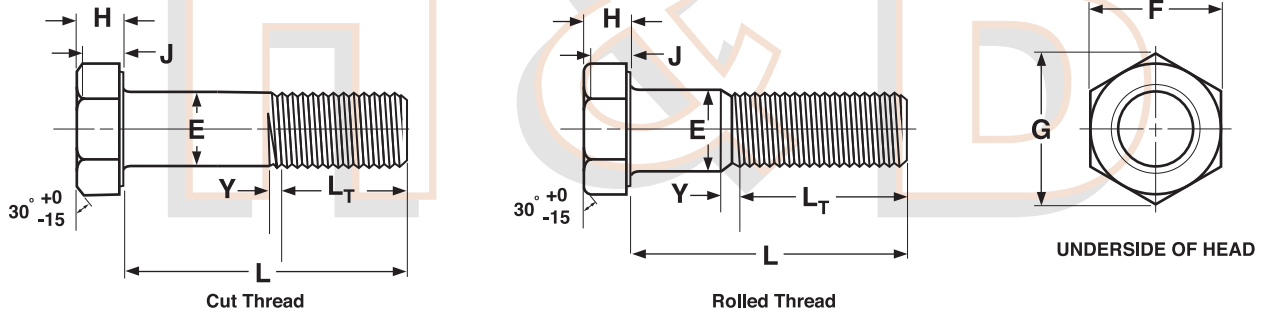

GRADE-9 HEX CAP SCREWS												Holo-Krome
Nominal or Basic Product Diameter		E		F			H			L _T		Y
		Body Diameter		Width Across Flats			Head Height			Thread Length		Transition Thread Length
		Max	Min	Basic	Max	Min	Basic	Max	Min	For Screw Lengths ≤ 6 in.	For Screw Lengths > 6 in.	
Ref	Ref	Max										
1/4	0.2500	0.2500	0.2450	7/16	0.438	0.428	3/16	0.194	0.181	0.750	1.000	0.250
5/16	0.3125	0.3125	0.3065	1/2	0.500	0.489	15/64	0.242	0.227	0.875	1.125	0.278
3/8	0.3750	0.3750	0.3690	9/16	0.562	0.551	9/32	0.289	0.273	1.000	1.250	0.312
7/16	0.4375	0.4375	0.4305	5/8	0.625	0.612	21/64	0.338	0.318	1.125	1.375	0.357
1/2	0.5000	0.5000	0.4930	3/4	0.750	0.736	3/8	0.386	0.364	1.250	1.500	0.385
9/16	0.5625	0.5625	0.5545	13/16	0.812	0.798	27/64	0.433	0.410	1.375	1.625	0.417
5/8	0.6250	0.6250	0.6170	15/16	0.938	0.922	15/32	0.481	0.456	1.500	1.750	0.455
3/4	0.7500	0.7500	0.7410	1-1/8	1.125	1.100	9/16	0.577	0.548	1.750	2.000	0.500
7/8	0.8750	0.8750	0.8660	1-5/16	1.312	1.285	21/32	0.672	0.640	2.000	2.250	0.556
1	1.0000	1.0000	0.9900	1-1/2	1.500	1.469	3/4	0.768	0.732	2.250	2.500	0.625

Tolerance on Length	Nominal Screw Size	Nominal Screw Length				
		Up to 1 in., incl.	Over 1 in. to 2-1/2 in., incl.	Over 2-1/2 in. to 4 in., incl.	Over 4 in. to 6 in., incl.	Longer than 6 in.
	1/4 to 3/8	-0.03	-0.04	-0.06	-0.10	-0.18
	7/16 and 1/2	-0.03	-0.06	-0.08	-0.10	-0.18
	9/16 to 3/4	-0.03	-0.08	-0.10	-0.10	-0.18
	7/8 and 1	-0.10	-0.14	-0.16	-0.20



GRADE-9 HEX CAP SCREW

Description	A cap screw made from medium carbon or alloy steel with head height approximately 25% higher than a standard cap screw.
Applications/ Advantages	Has greater tensile strength than a Grade-8. Designed for use in heavy machinery and equipment subject to harsh environmental and fatigue conditions.
Material	AISI 8637 / 8640 / 8740 Medium Carbon Alloy Steel wire or 4340 Alloy Steel bar stock
Hardness	Rockwell C38 - C42
Proof Load	140,650 psi.
Yield Strength*	159,500 psi. minimum
Tensile Strength	180,000 psi. minimum
Elongation*	10% minimum (all diameters)
Reduction of Area*	35% minimum (all sizes)
Plating	Steel EcoGuard™ 1000-hour Gray/Silver finish

