

# Cap Screws & Bolts

# Head & Thread Dimensions

Grades 5 & 8  
Cap Screws

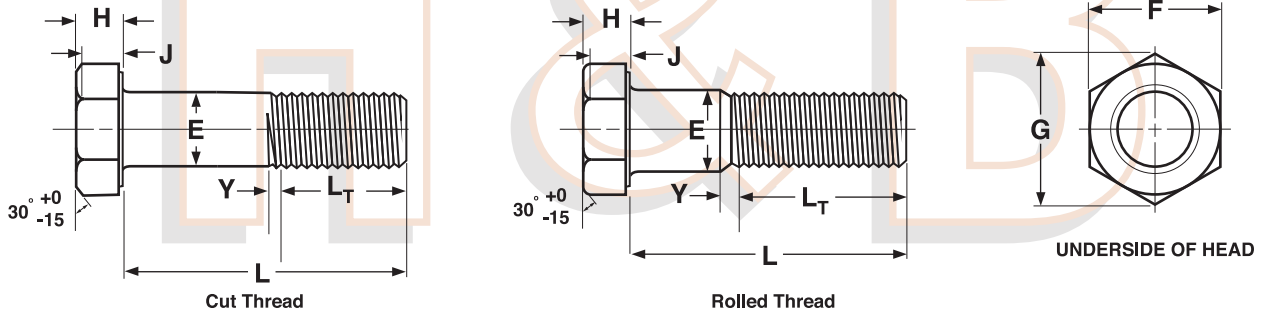

⊥Length of a cap screw is measured from the underhead bearing surface to the extreme end of the screw.

HEX CAP SCREWS															ASME B18.2.1-1996	
Nominal or Basic Product Diameter		E		F			G		H			J	L <sub>T</sub>		Y	
		Body Diameter		Width Across Flats			Width Across Corners		Head Height			Wrenching Height	Thread Length		Transition Thread Length	
		Max	Min	Basic	Max	Min	Max	Min	Basic	Max	Min		Min	For Screw Lengths ≤ 6 in.		For Screw Lengths > 6 in.
Ref	Ref	Max														
1/4	0.2500	0.2500	0.2450	7/16	0.438	0.428	0.505	0.488	5/32	0.163	0.150	0.106	0.750	1.000	0.250	
5/16	0.3125	0.3125	0.3065	1/2	0.500	0.489	0.577	0.557	13/64	0.211	0.195	0.140	0.875	1.125	0.278	
3/8	0.3750	0.3750	0.3690	9/16	0.562	0.551	0.650	0.628	15/64	0.243	0.226	0.160	1.000	1.250	0.312	
7/16	0.4375	0.4375	0.4305	5/8	0.625	0.612	0.722	0.698	9/32	0.291	0.272	0.195	1.125	1.375	0.357	
1/2	0.5000	0.5000	0.4930	3/4	0.750	0.736	0.866	0.840	5/16	0.323	0.302	0.215	1.250	1.500	0.385	
9/16	0.5625	0.5625	0.5545	13/16	0.812	0.798	0.938	0.910	23/64	0.371	0.348	0.250	1.375	1.625	0.417	
5/8	0.6250	0.6250	0.6170	15/16	0.938	0.922	1.083	1.051	25/64	0.403	0.378	0.269	1.500	1.750	0.455	
3/4	0.7500	0.7500	0.7410	1-1/8	1.125	1.100	1.299	1.254	15/32	0.483	0.455	0.324	1.750	2.000	0.500	
7/8	0.8750	0.8750	0.8660	1-5/16	1.312	1.285	1.516	1.465	35/64	0.563	0.531	0.378	2.000	2.250	0.556	
1	1.0000	1.0000	0.9900	1-1/2	1.500	1.469	1.732	1.675	39/64	0.627	0.591	0.416	2.250	2.500	0.625	
1-1/8	1.1250	1.1250	1.1140	1-11/16	1.688	1.631	1.949	1.859	11/16	0.718	0.658	0.461	2.500	2.750	0.714	
1-1/4	1.2500	1.2500	1.2390	1-7/8	1.875	1.812	2.165	2.066	25/32	0.813	0.749	0.530	2.750	3.000	0.714	
1-1/2	1.5000	1.5000	1.4880	2-1/4	2.250	2.175	2.598	2.480	1-5/16	0.974	0.902	0.640	3.250	3.500	0.833	

Tolerance on Length	Nominal Screw Size	Nominal Screw Length				
		Up to 1 in., incl.	Over 1 in. to 2-1/2 in., incl.	Over 2-1/2 in. to 4 in., incl.	Over 4 in. to 6 in., incl.	Longer than 6 in.
	1/4 to 3/8	-0.03	-0.04	-0.06	-0.10	-0.18
	7/16 and 1/2	-0.03	-0.06	-0.08	-0.10	-0.18
	9/16 to 3/4	-0.03	-0.08	-0.10	-0.10	-0.18
7/8 and 1	....	-0.10	-0.14	-0.16	-0.20	
1-1/8 to 1-1/2	....	-0.12	-0.16	-0.18	-0.22	



**GRADE-5 HEX CAP SCREW**

<b>Description</b>	A cap screw made from medium carbon steel and heat-treated.
<b>Applications/ Advantages</b>	Has greater tensile strength than a Grade-2. Yield-to-tensile ratio is the lowest of all heat treated steels.
<b>Heat Treatment</b>	Grade-5 cap screws shall be heat treated, oil or water quenched, at the option of the manufacturer, and tempered at a minimum tempering temperature of 800°F.
<b>Material</b>	Medium carbon steel. Use of an alloy steel is also acceptable.
<b>Core Hardness</b>	<i>1/4 through 1 in. diameter, all lengths:</i> Rockwell C25 - C34. <i>1-1/8 through 1-1/2 in. diameter, all lengths:</i> Rockwell C19 - C30.
<b>Surface Hardness</b>	<i>1/4 through 1 in. diameter, all lengths:</i> Rockwell 30N54 maximum. <i>1-1/8 through 1-1/2 in. diameter, all lengths:</i> Rockwell 30N50 maximum.
<b>Proof Load</b>	<i>1/4 through 1 in. diameter, all lengths:</i> 85,000 psi. <i>1-1/8 through 1-1/2 in. diameter, all lengths:</i> 74,000 psi.
<b>Yield Strength*</b>	<i>1/4 through 1 in. diameter, all lengths:</i> 92,000 psi. minimum <i>1-1/8 through 1-1/2 in. diameter, all lengths:</i> 81,000 psi. minimum
<b>Tensile Strength</b>	<i>1/4 through 1 in. diameter, all lengths:</i> 120,000 psi. minimum <i>1-1/8 through 1-1/2 in. diameter, all lengths:</i> 105,000 psi. minimum
<b>Elongation*</b>	14% minimum (all diameters)
<b>Reduction of Area*</b>	35% minimum (all sizes)
<b>Plating</b>	See Appendix-A for plating information.



**GRADE-8 HEX CAP SCREW**

<b>Description</b>	A cap screw made from medium carbon alloy steel and heat-treated.
<b>Applications/ Advantages</b>	Has greater tensile strength than a Grade-5. Designed for use in high stress applications. See specifications below for more information on how the Grade-8 exceeds the strength of a Grade-5.
<b>Heat Treatment</b>	Grade-8 cap screws shall be heat-treated, oil-quenched and tempered at a minimum temperature of 800°F.
<b>Material</b>	Medium carbon alloy steel. Note: For diameters 1/4 through 7/16 inch, it is permissible to use AISI 1541 steel.
<b>Core Hardness</b>	<i>1/4 through 1-1/2 in. diameter, all lengths:</i> Rockwell C33 - C39.
<b>Surface Hardness</b>	<i>1/4 through 1-1/2 in. diameter, all lengths:</i> Rockwell 30N58.6 maximum.
<b>Proof Load</b>	<i>1/4 through 1-1/2 in. diameter, all lengths:</i> 120,000 psi.
<b>Yield Strength*</b>	<i>1/4 through 1-1/2 in. diameter, all lengths:</i> 130,000 psi. minimum
<b>Tensile Strength</b>	<i>1/4 through 1-1/2 in. diameter, all lengths:</i> 150,000 psi. minimum
<b>Elongation*</b>	12% minimum (all diameters)
<b>Reduction of Area*</b>	35% minimum (all sizes)
<b>Plating</b>	See Appendix-A for plating information.

•These properties are tested only on machined specimens when the testing machine cannot provide for full testing of the parts.  
 ••Product standards require the manufacturer's head marking to appear on the top of all cap screws 1/4" diameter and larger. "X" represents on location such a marking may appear.