

METRIC FASTENERS

RIVET NUTS (Blind Threaded Inserts)

Flat Head

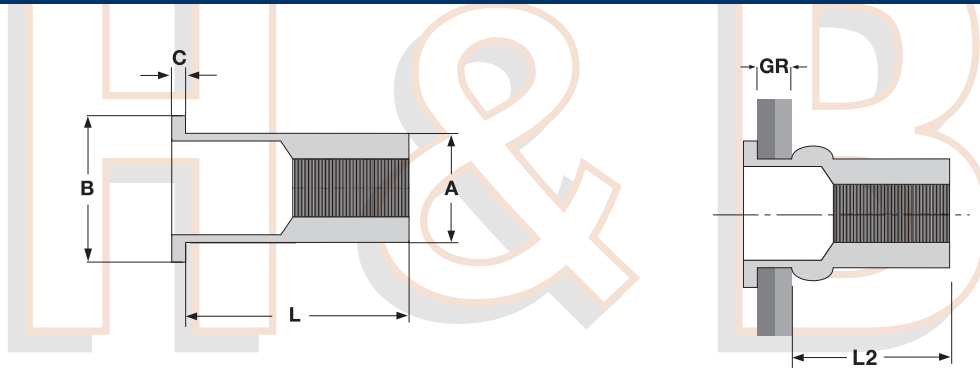

FLAT HEAD, NON-RIBBED BLIND THREADED INSERT

Thread Size - Ultimate Grip	L		A		B		C	Hole Size		L2	GR
	Body Length		Body Diameter		Head Diameter		Head Height			Installed Length	Grip Range
	Max	Min	Max	Min	Max	Min	Nom	Max	Min	Ref	
M3 x 0.5 ISO	8.38	7.62	3.93	3.83	7.06	6.30	0.63	4.02	3.94	5.61	0.25 - 1.00
M3 x 0.5 ISO	9.13	8.37	3.93	3.83	7.06	6.30	0.63	4.02	3.94	5.61	1.00 - 1.75
M4 x 0.7 ISO	11.38	10.62	5.61	5.51	9.39	8.63	0.81	5.68	5.60	7.08	0.25 - 2.00
M4 x 0.7 ISO	12.38	11.62	5.61	5.51	9.39	8.63	0.81	5.68	5.60	7.08	2.00 - 3.00
M5 x 0.8 ISO	16.38	15.62	7.13	7.03	11.55	10.79	1.22	7.28	7.20	10.09	2.00 - 3.50
M5 x 0.8 ISO	17.88	17.12	7.13	7.03	11.55	10.79	1.22	7.28	7.20	10.09	3.50 - 5.00
M6 x 1.0 ISO	17.38	16.62	8.43	8.33	13.81	13.05	1.47	8.58	8.50	10.58	2.00 - 3.50
M6 x 1.0 ISO	18.88	18.12	8.43	8.33	13.81	13.05	1.47	8.58	8.50	10.58	3.50 - 5.00
M8 x 1.25 ISO	20.38	19.62	10.48	10.38	17.03	16.27	1.57	10.58	10.50	11.83	3.00 - 5.00
M8 x 1.25 ISO	22.38	21.62	10.48	10.38	17.03	16.27	1.57	10.58	10.50	11.83	5.00 - 7.00

Description	A cylindrical internally threaded fastener with a thicker wall in the area where the insert collapses. The fastener is open at both ends with a circular flange at one end that can be installed into a prepared hole from the blind side of the ultimate fastening. Insert is threaded onto mandrel of installation tool and positioned into hole. As mandrel is pulled back, the insert is expanded into the base material it is now gripping. Installation is complete when the mandrel of the tool is removed from the set insert.
Applications / Advantages	One popular use is as a leg leveler.
Material	Aluminum: 6053 or 5056 Aluminum alloy